

## ISOLATING VALVES VALVES

DN 150 a 2000



03/02/2021

EFSFAESPMOTLA00

### Butterfly Valve EUROSTOP - Motorized type - Heavy Duty Water Treatment Version



Double eccentric butterfly valve for waste water with automatic joint in NBR  
Body and butterfly in ductile iron painted with 300 micron epoxy powder.  
Range from DN150 to DN2000mm for PFA10 pressures at 25 bar.

### Field of application

Butterfly valves are isolating valves used on water supply networks, in the interconnections of network, in the factories, in pumping stations, on the general networks and on the fire protection networks in the industrial sites.

Butterfly valves are compatible with drinking water and raw water with grid filtration. They will be installed on water networks in factories, in valves chambers or buried.

Their main advantages are:

- Low pressure loss
- Good performance thanks to the choice of the materials, the coatings and the design
- Easy operation per mechanism of the worm type/without end
- Mechanisms equipped with a standardized flange carry-accessory for buried version and motorizable version

### Range

The Eurostop butterfly valve for waste water is available in different versions: manual, underground (see related technical data sheets), motorized and predisposed for motorization.

Motorized version supplied with gearbox and clockwise closing actuator (FSH-CC). Counterclockwise closing version on request.

Motorization with AUMA S2 actuator - 15 min, 400 V -3 - 50Hz, IP68.8, KS anti-condensation heater 230V

# ISOLATING VALVES VALVES

DN 150 a 2000



03/02/2021

EFSPAESPOTLA00

## Material and coating

Versions DN150-800 PN10 - DN150-700 PN16 - DN150-600 PN25

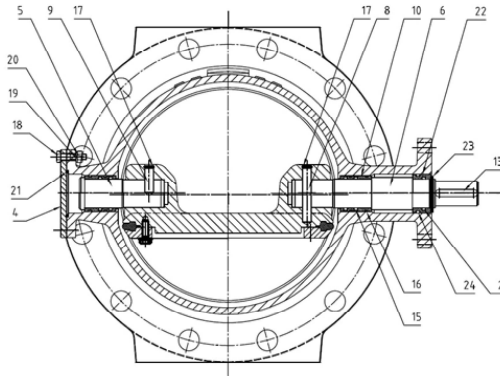
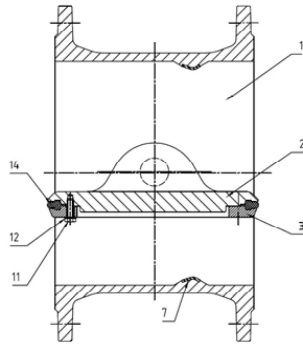

Item	Description	Material	Coating
1	Body	Ductile Iron GS500-7	Epoxy powder thickness mini 300 microns
2	Disc	Ductile Iron GS500-7	
3	Reitaning ring	Stainless Steel AISI 316L	-
4	Cover	Stainless Steel X2CrNiMo17-12-2	-
5	Rear Shaft	Stainless Steel EN 10088-3 DUPLEX N°1.4462	-
6	Back Shaft	Stainless Steel EN 10088-3 DUPLEX N°1.4462	-
7	Seat	Stainless Steel EN 10088-2 X2CrNiMo 17,12,2 (316L)	-
8	Pin	Stainless Steel EN 10088-3 X5CrNiCuNb 16-4 (630)	-
9	Pin	Stainless Steel EN 10088-3 X5CrNiCuNb 16-4 (630)	-
10	Bush	Bronze -Aluminium EN 1982 CuAl11Ni4F	-
11	Screw	Stainless Steel A4	-
12	Washer	Stainless Steel A4	-
13	Tab	Stainless Steel C40	-
14	Gasket	NBR	-
15-16	O-ring	NBR	-
17	Seeger	Stainless Steel EN 10088-3 X5CrNi 18-10	-
18	Screw	Stainless Steel EN 10088-3 X5CrNiMo 17-12-2	-
19	Washer	Stainless Steel EN 10088-3 X5CrNiMo 17-12-2	-
20	Nut	Stainless Steel EN 10088-3 X5CrNiMo 17-12	-
21	O-ring	NBR	-
22	Bush	POM-C	-
23	Seeger	Stainless Steel EN 10088-3 X5CrNi 18-10	-
24-25	O-ring	NBR	-

# ISOLATING VALVES VALVES

DN 150 a 2000



03/02/2021

EFSFAESPMOTLA00

Versions DN900-2000 PN10 - DN800-2000 PN16 - DN700-2000 PN25

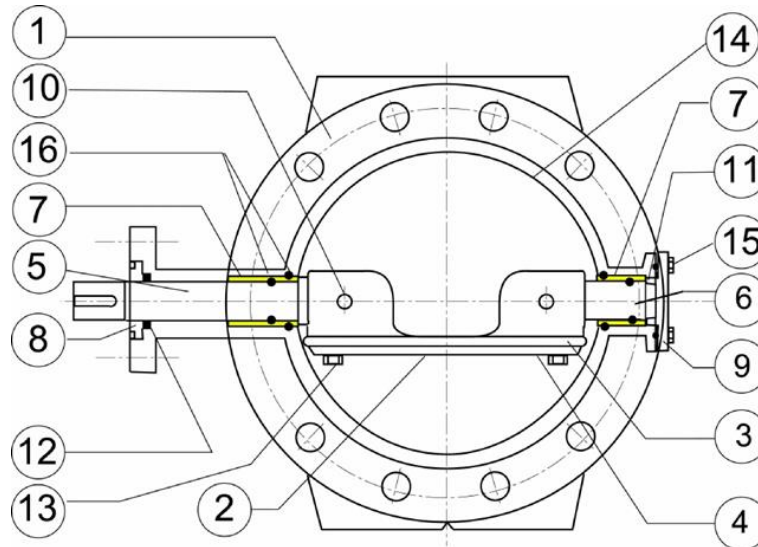

Item	Description	Material	Coating
1	Body	Ductile Iron GS500-7	Epoxy powder thickness mini 300 microns
2	Disc	Ductile Iron GS500-7	
3	Gasket	NBR	-
4	Retaining ring	Stainless steel AISI 316L	-
5	Back shaft	Stainless steel EN 10088-3 DUPLEX N°1.4462	-
6	Rear shaft		-
7	Bush	Bronze-Alluminium EN 1982 CuAl11Ni4F	-
8	Ring	Gunmetal EN 1982 CuSn5Zn5Pb5	-
9	Back cover	Carbon steel SR235JR	Epoxy powder thickness mini 300 microns
10	Pin	Stainless steel EN 10088-3 X5CrNiCuNb 16-4 (630)	-
11	Lock nut	Bronze EN 1982 CuSn5Zn5Pb5-C491K	-
12	Sealing	PTFE	-
13	Fasteners	Stainless steel A4	-
14	Seat	Stainless steel EN 10088-2 X2CrNiMo 17,12,2 (316L)	-
15	Fasteners	Stainless steel A4	-
16	O-ring	NBR	-

# ISOLATING VALVES VALVES

DN 150 a 2000



03/02/2021

EFSFAESPMOTLA00

## Dimensions and mass

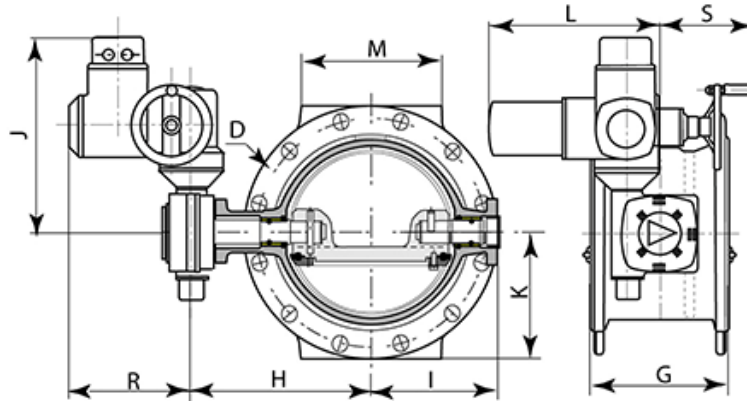

**PN10 - Standard version with short duty actuator S2-15 min, 400 V -3 – 50Hz, IP68.8, KN protection and heater 230 V.**

DN	G	H	I	J	K	L	M	D	R	S	Mass
mm	mm	mm	mm	mm	mm	mm	mm	mm	mm	mm	kg
150	210	215	142.9	390	143	315	150	285	238	199	56
200	230	240	171.0	390	170	315	180	340	238	199	67
250	250	292	215.3	390	200	315	230	400	238	199	83
300	270	319	239.3	390	228	315	250	455	238	199	104
350	290	340	258.3	415	253	328	260	505	238	186	132
400	310	371	311.4	417	283	346	310	565	248	191	161
450	330	427	342.4	422	308	363	340	615	248	174	181
500	350	452	367.4	422	335	363	320	670	248	174	230
600	390	524	421.4	549	390	365	300	780	238	149	331
700	430	594	495.5	551	448	383	440	895	248	154	472
800	470	675	569.5	556	508	408	480	1015	248	129	665
900	510	724	623	618	558	442	570	1115	247	94	861
1000	550	815	707	618	615	442	600	1230	247	94	1249
1200	630	909	842	748	728	482	750	1455	247	54	1831
1400	710	1051	953	842	838	634	850	1675	285	79	2544
1500	750	1102	1004	842	893	634	900	1785	285	79	2905
1500	790	1154	1056	842	958	634	950	1915	285	79	3520
1800	870	1331	1179	962	1058	597	1000	2115	247	-	4997
2000	950	1526	1367	1077	1173	784	1050	2345	285	-	8418

**PN16 - Standard version with short duty actuator S2-15 min, 400 V -3 – 50Hz, IP68.8, KN protection and heater 230 V.**

DN	G	H	I	J	K	L	M	D	R	S	Mass
mm	mm	mm	mm	mm	mm	mm	mm	mm	mm	mm	kg
150	210	215	142.9	390	143	315	150	285	238	199	56
200	230	240	171.9	390	170	315	180	340	238	199	67
250	250	292	215.3	390	200	315	230	400	238	199	85
300	270	321	239.3	415	228	328	250	455	238	186	111

**ISOLATING VALVES  
VALVES**  
DN 150 a 2000



03/02/2021

**EFSFAESPMOTLA00**

DN	G	H	I	J	K	L	M	D	R	S	Mass
<i>mm</i>	<i>mm</i>	<i>mm</i>	<i>mm</i>	<i>mm</i>	<i>mm</i>	<i>mm</i>	<i>mm</i>	<i>mm</i>	<i>mm</i>	<i>mm</i>	<i>kg</i>
350	290	340	280.4	417	260	346	260	520	248	191	156
400	310	407	322.4	422	290	363	310	580	248	174	185
450	330	445	342.4	549	320	365	340	640	238	149	248
500	350	470	367.4	549	358	365	320	715	238	149	294
600	390	550	451.5	551	420	383	300	840	248	154	440
700	430	627	521.5	556	455	408	420	910	248	129	566
800	470	713	602	618	513	442	450	1025	247	94	986
900	510	764	653	748	563	482	550	1125	247	54	1044
1000	550	815	748	748	628	482	600	1255	247	54	1479
1200	630	950	852	844	743	634	750	1485	285	79	2389
1400	710	1125	973	1000	843	597	850	1685	247	-	3622
1500	750	1156	1077	1001	933	597	900	1865	247	-	4313
1600	790	1229	1119	1041	965	699	950	1930	285	14	4948
1800	870	1431	1272	1141	1065	784	1000	2130	285	-	7039
2000	950	1526	1367	1141	1173	784	1050	2345	285	-	8418

**PN25 - Standard version with short duty actuator S2-15 min, 400 V -3 – 50Hz, IP68.8, KN protection and heater 230 V.**

DN	G	H	I	J	K	L	M	D	R	S	Mass
<i>mm</i>	<i>mm</i>	<i>mm</i>	<i>mm</i>	<i>mm</i>	<i>mm</i>	<i>mm</i>	<i>mm</i>	<i>mm</i>	<i>mm</i>	<i>mm</i>	<i>kg</i>
150	210	217	147.9	390	150	315	150	300	238	199	59
200	230	272	190.3	390	180	315	180	360	238	199	83
250	250	297	214.3	415	213	328	230	425	238	186	108
300	270	321	260.4	417	243	346	250	485	248	191	142
350	290	376	290.4	422	278	363	310	555	248	174	196
400	310	425	321.4	549	310	365	310	620	238	149	250
450	330	471	371.4	549	335	365	340	670	238	149	324
500	350	498	398.5	551	365	383	300	730	248	154	376
600	390	581	474.5	632	423	443	350	845	248	94	593
700	430	665	552	618	480	442	420	960	247	94	975
800	470	713	645	748	543	482	450	1085	247	54	1243
900	510	788	695	748	593	482	550	1185	247	54	1725
1000	550	856	756	844	660	634	620	1320	285	79	2123
1200	630	1024	872	962	765	597	760	1530	247	-	3430
1400	710	1126	1016	1000	878	699	850	1755	285	14	4600
1500	750	1186	1078	1081	933	784	900	1865	285	-	3117
1600	790	1328	1169	1081	988	784	950	1975	285	-	6265

**Gearbox type and handwheel**

**Motorized type PN10**

DN	Gearbox AUMA type	Actuator AUMA Type	ISO 5210	Operating Time	Speed	Operating Torque	Setting torque
<i>mm</i>				<i>s</i>	<i>turn/mn</i>	<i>Nm</i>	<i>Nm</i>
150	GS 50.3 – F10	SA 07.6	F10	35	22	8	20

# ISOLATING VALVES VALVES

DN 150 a 2000



03/02/2021

EFSSFAESPMOTLA00

DN	Gearbox AUMA type	Actuator AUMA Type	ISO 5210	Operating Time	Speed	Operating Torque	Setting torque
<i>mm</i>				<i>s</i>	<i>turn/mn</i>	<i>Nm</i>	<i>Nm</i>
200	GS 50.3 – F10	SA 07.6	F10	35	22	12	20
250	GS 50.3 – F10	SA 07.6	F10	48	16	21	27
300	GS 50.3 – F10	SA 07.6	F10	48	16	30	40
350	GS 63.3 – F12	SA 07.6	F10	70	11	39	51
400	GS 63.3 – F12	SA 10.2	F10	70	11	60	68
450	GS 80.3 – F14	SA 10.2	F10	99	8	70	92
500	GS 80.3 – F14	SA 10.2	F10	99	8	90	117
600	GS 100.3+VZ4.3 – F16	SA 07.6	F10	142	22	35	46
700	GS 100.3+VZ4.3 – F16	SA 10.2	F10	142	22	52	68
800	GS 125.3+VZ4.3 – F25	SA 10.2	F10	142	22	77	100
900	GS 160.3+GZ160.3 - F25	SA 10.2	F10	207	32	47	61
1000	GS 160.3+GZ160.3 - F30	SA 10.2	F10	207	32	65	84
1200	GS 200.3+GZ200.3 - F30	SA 10.2	F10	206	63	60	78
1400	GS 250.3+GZ250.3 - F35	SA 14.2	F14	283	45	93	121
1500	GS 250.3+GZ250.3 - F35	SA 14.2	F14	283	45	110	142
1600	GS 250.3+GZ250.3 - F35	SA 14.2	F14	283	45	130	169
1800	GS 315+GZ30 - F40	SA 10.2	F10	404	63	75	98
2000	GS 315+GZ30 - F40	SA 14.2	F14	404	63	102	133

# ISOLATING VALVES VALVES

DN 150 a 2000



03/02/2021

EFSSFAESPMOTLA00

## Motorized type PN16

DN	Gearbox AUMA type	Actuator AUMA Type	ISO 5210	Operating Time	Speed	Operating Torque	Setting torque
<i>mm</i>				<i>s</i>	<i>turn/mn</i>	<i>Nm</i>	<i>Nm</i>
150	GS 50.3 – F10	SA 07.6	F10	35	22	8	20
200	GS 50.3 – F10	SA 07.6	F10	35	22	17	27
250	GS 50.3 – F10	SA 07.6	F10	48	16	29	38
300	GS 63.3 – F12	SA 07.6	F10	48	16	42	55
350	GS 63.3 – F12	SA 10.2	F10	70	11	59	77
400	GS 80.3 – F14	SA 10.2	F10	72	11	83	108
450	GS 100.3+VZ4.3 – F14	SA 07.6	F10	98	32	26	34
500	GS 100.3+VZ4.3 – F14	SA 07.6	F10	98	32	33	43
600	GS 100.3+VZ4.3 – F16	SA 10.2	F10	142	22	59	76
700	GS 125.3+VZ4.3 – F25	SA 10.2	F10	142	22	84	109
800	GS 160.3+GZ160.3 - F30	SA 10.2	F10	147	45	64	83
900	GS 160.3+GZ160.3 - F30	SA 10.2	F10	207	32	83	108
1000	GS 200.3+GZ200.3 - F30	SA 10.2	F10	206	63	65	85
1200	GS 250.3+GZ250.3 - F35	SA 14.2	F14	202	63	104	135
1400	GS 315+GZ30 - F40	SA 10.2	F10	283	90	65	85
1500	GS 315+GZ30 - F40	SA 10.2	F10	283	90	77	100
1600	GS 315+GZ30 - F40	SA 14.2	F14	283	90	94	123
1800	GS 400+GZ35 - F48	SA 14.2	F14	411	63	126	164
2000	GS 400+GZ35 - F48	SA 14.2	F14	411	63	161	209

# ISOLATING VALVES VALVES

DN 150 a 2000



03/02/2021

EFSFAESPMOTLA00

## Motorized type PN25

DN	Gearbox AUMA type	Actuator AUMA Type	ISO 5210	Operating Time	Speed	Operating Torque	Setting torque
mm				s	turn/mn	Nm	Nm
150	GS 50.3 – F10	SA 07.6	F10	35	22	13	20
200	GS 50.3 – F10	SA 07.6	F10	35	22	28	36
250	GS 63.3 – F12	SA 07.6	F10	48	16	43	57
300	GS 63.3 – F12	SA 10.2	F10	48	16	69	90
350	GS 80.3+VZ4.3 – F14	SA 10.2	F10	72	11	88	114
400	GS 100.3+VZ4.3 – F14	SA 07.6	F10	69	45	32	42
450	GS 100.3+VZ4.3 – F16	SA 07.6	F10	98	32	45	58
500	GS 100.3+VZ4.3 – F16	SA 10.2	F10	98	32	59	77
600	GS 160.3+GZ160.3 – F25	SA 10.2	F10	147	45	47	61
700	GS 160.3+GZ160.3 – F30	SA 10.2	F10	147	45	70	91
800	GS 200.3+GZ200.3 – F30	SA 10.2	F10	144	90	65	85
900	GS 200.3+GZ200.3 – F35	SA 10.2	F10	206	63	84	109
1000	GS 250.3+GZ250.3 – F35	SA 14.2	F14	202	63	115	150
1200	GS 315+GZ30 – F40	SA 10.2	F10	283	90	74	96
1400	GS 315+GZ30 – F40	SA 14.2	F14	283	90	110	143
1500	GS 400+GZ35 – F48	SA 14.2	F14	288	90	133	173
1600	GS 400+GZ35 – F48	SA 14.2	F14	288	90	153	199

## Applicable Standards

### Hydraulic test

Every single butterfly valve is subjected to hydraulic final test with the purpose of verifying the accordance with the prescriptions ISO 5208:

- Body test at 1,5 time the PFA (open valve);
- Seat test at 1,1 time the PFA (closed valve).

### Product test

- Control of manoeuvre torque (MOT and mST) as defined in the EN1074
- Control of coating: test of thickness, holiday test, impact test, MIBK test

### Conformity to the standards

#### Product:

- EN 1074 – 1 and 2
- EN 593
- ISO 10631

<b>ISOLATING VALVES</b> <b>VALVES</b> DN 150 a 2000		03/02/2021
		<b>EFSFAESPMOTLA00</b>

**Plant test:**

- ISO 5208

**Flanges dimension:**

- ISO 5752 series 14

**Flanges drilling:**

- EN 1092-2
- ISO 7005-2

**Suitability for potable water:**

- Italian CM 102 of 02/12/78
- Conformity to foreign norms: KTW (Germany), WRC (U.K.), ACS (France)

**Marking**

**On the body like EN19:**

- Nominal diameter in mm (DN);
- Nominal pressure in bar (PN);
- Type of ductile iron;
- Manufacturer's logo;
- Model code;
- Fusion date.

**On the label like EN19:**

- Nominal diameter in mm (DN);
- Nominal pressure in bar (PN);
- Maximum operating pressure (PFA);
- Closing direction;
- Model code;
- Manufacturing order, Order confirmation;
- Manufacturer's logo.

**On the disc:**

- Nominal diameter in mm (DN);
- Nominal pressure in bar (PN);
- Type of ductile iron;
- Manufacturer's logo;
- Model code.

The marking of the valves manufactured by Saint-Gobain refers to the EN 1074-2 and EN 19 international standards.

Markings are either integral markings, cast in the body, or markings made on plates, securely fixed to the body, in accordance with the EN 19 standard specifications.

<b>ISOLATING VALVES</b> <b>VALVES</b> DN 150 a 2000		03/02/2021
		<b>EFSFAESPMOTLA00</b>

Specifications EN19			Saint-Gobain valves process
Table1-Valve markings		Requirements	
1	DN	EN 19 § 4.2.1 Mandatory markings Shall be integral markings or on a marking plate	Integral
2	PN		Integral
3	Material		Integral
4	Manufacturer's name or trade mark		Plate
11	Reference to Standard	EN 19 § 4.3 Supplementary markings Items 7 to 21 in Table 1 are optional	Integral
12	Melt identification		Integral
16	Quality test		Printed on body
18	Manufacturing date		Plate
21	Closing direction		Plate + sticker on body



## Valve selection

The butterfly valves are generally used as isolating devices type on/off. In some particular case, in which there's low differences of pressure and low flow rate variation can be used like regulating devices, considering the hydraulic parameters necessary to avoid the cavitation risk.

To do the right dimensioning of butterfly valve it's necessary to know the followings parameters:

- Upstream hydrostatic pressure (that is the hydrostatic pressure with valve in closed position)
- The maximum speed in water pipe (generally expressed in l/s) or the nominal diameter and the project flow rate from which it is gained the speed  $V=Q/A$

Moreover it's necessary to control that the maximum speed in water pipe have to be equal or inferior to 5m/s, and the exercise temperature have to be between 0°C and 40 °C.

## Hydraulic features

The head loss  $\Delta h$  are variable in function of valve open degree and can be calculated with the following expression:

# ISOLATING VALVES VALVES

DN 150 a 2000



03/02/2021

EFSFAESPMOTLA00

$$\Delta h = \frac{\zeta \cdot v^2}{2 \cdot g}$$

with  $\Delta h$  = head loss (m),  $\zeta$  = head loss coefficient (dimensional),  $v$  = nominal speed (m/s),  $g = 9,81$  (m/s<sup>2</sup>)

The head loss coefficient can be estimated from this diagram:

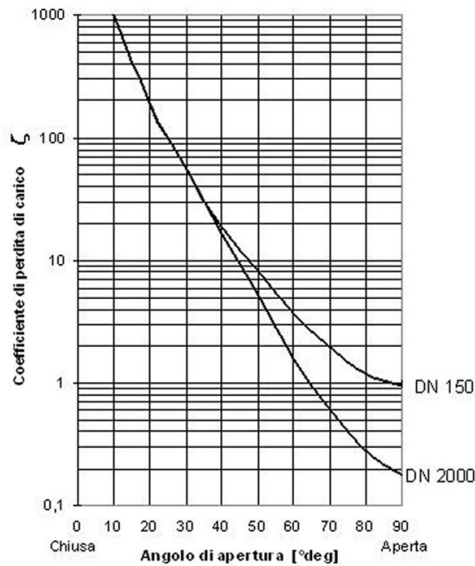

Determinates the head loss  $\Delta h$  it's possible to calculate the flow rate  $Q$  in m<sup>3</sup>/h with the following expression (the same expression can be used to, having the project flow rate  $Q$ , to determinate the head loss  $\Delta h$  without using the head loss coefficient):

$$Q = K_v \sqrt{\frac{\Delta h}{10.2}}$$

in which 10,2 is a corrective factor in meters, and  $K_v$  is the flow rate coefficient in m<sup>3</sup>/h, determinable from the following diagram in function of valve open degree:

VALVOLA A FARFALLA - BUTTERFLY VALVE

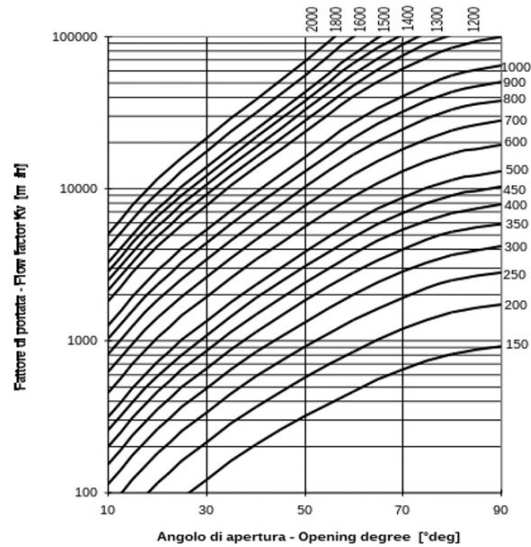

**Example:** Valve DN600 mm -  $\Delta h = 3$  m

From the diagram with valve open to 100% the coefficient Kv is 20000 m<sup>3</sup>/h. Using this data in the flow rate expression:

$$Q = 20000 \times \sqrt{3 / 10,2} = 10850 \text{ m}^3/\text{h}$$

Otherwise it's possible to calculate the head loss with valve completely open, having the project flow rate Q, in function of DN, using the following diagram:

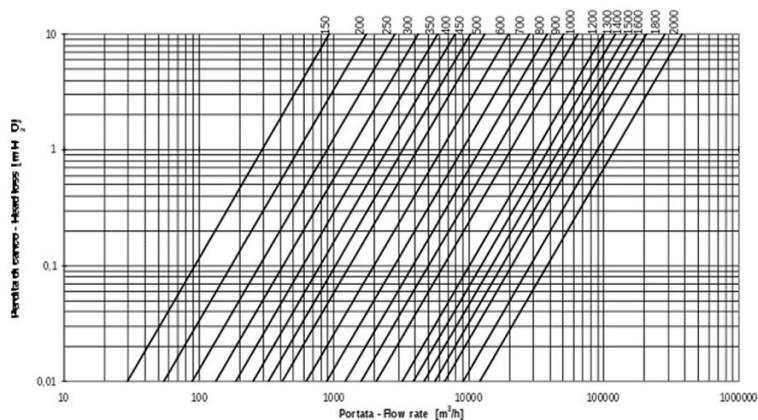

**Cavitation**

If the butterfly valve is used only like isolating device there's not cavitation risk.

In the particular case in which it's used like regulating device, this can be possible only respecting the following parameters:

- The valve open degree have to be between 30° and 90° (valve completely open)
- The downstream pressure P<sub>2</sub> have to be:  $P_2 \geq 0,7 \cdot P_1 - 2,8$  with P<sub>1</sub> upstream pressure.

**Instructions for use**

<p style="text-align: center;"><b>ISOLATING VALVES</b> <b>VALVES</b> DN 150 a 2000</p>		<p style="text-align: center;">03/02/2021</p> <hr/> <p style="text-align: center;"><b>EFSFAESPMOTLA00</b></p>
--	---	---

### Storage

The butterfly valve will have to be held (if possible) in covered places, the most possible protected from the sun (maximum allowable temperature 70°C in accordance to EN 1074), from the rain and generally from the atmospheric agents. Moreover it will have to be avoided that the seal of the same air valves come to contact with powder or earth.

### Installation

The butterfly valves are generally installed with retaining ring mounted in the opposite way respect to the direction of flow rate to permit the substitution of gasket without dismounting the valve from pipeline. In any case it is possible to install the butterfly valve with flow rate in opposite direction and also, if required, in vertical position. We recommend to install the butterfly with the operating device on the hydraulic right side of pipeline.

It's possible to install the butterfly valve both in chamber valve that underground (choosing the right configuration).

We recommend to insert a dismounting joint for the operation of maintenance.

### Maintenance

The butterfly valve does not require a particular maintenance, all parts subjected to wear are perfectly auto-lubricating. In any case, if for a long time will be not used, it is necessary to evaluate the functioning of valve doing (at least one time for year) some manoeuvre of opening-closing.

All the maintenance operation have to be do after the total emptying of pipeline (no flow rate and pressure) to avoid every risk to the people during this operation.

In presence of particularly exercise condition or damage due to external cause, it will be necessary some maintenance operation. In this case the particular shape of EUROSTOP butterfly valve permits the simple gasket substitution without the dismounting of valve from pipeline (if the dismounting joint is present).

### Accessories

To adapt the butterfly valves to the different exercise and installation conditions required, they can be equipped with particular accessories used in combination with control devices: please refer to data sheet for accessories.

The technical features in this document are not contractual and can be changed without preliminary notification due to the continuous technical progress of product.