

ISOLATING VALVES VALVES

DN 150 to 2000



03/11/2021

RSEVP27MAN250

Butterfly Valve EUROSTOP Manual type - Reinforced version (Heavy Duty)



Flanged Butterfly Valve (flange-flange) with joint in the automatic butterfly (JPA) with double eccentricity and long spacing between the flanges.

Ductile iron body and butterfly covered with blue epoxy powder 300 microns mini.

Range from DN150 to DN2000mm for pressures of PFA10 to 25 bar.

Field of application

Butterfly valves are isolating valves used on water supply networks, in the interconnections of network, in the factories, in pumping stations, on the general networks and on the fire protection networks in the industrial sites.

Butterfly valves are compatible with drinking water and raw water with grid filtration. They will be installed on water networks in factories, in valves chambers or buried.

Their main advantages are:

- Low pressure loss
- Good performance thanks to the choice of the materials, the coatings and the design
- Easy operation per mechanism of the worm type/without end
- Mechanisms equipped with a standardized flange carry-accessory for buried version and motorizable version

Range

The EUROSTOP butterfly valve is available in different configuration: manual, buried service, motorized and motorizable (for this three last configuration see the specific TDS).

References Manual Type

DN valve <i>mm</i>	Description <i>Version</i>	References PN10	References PN16	References PN25
150	Manually	please contact us	please contact us	please contact us
200	Manually	please contact us	please contact us	please contact us
250	Manually	please contact us	please contact us	please contact us
300	Manually	please contact us	please contact us	please contact us
350	Manually	please contact us	please contact us	please contact us
400	Manually	please contact us	please contact us	please contact us
450	Manually	please contact us	please contact us	please contact us
500	Manually	please contact us	please contact us	please contact us
600	Manually	please contact us	please contact us	please contact us

ISOLATING VALVES
VALVES
 DN 150 to 2000



03/11/2021

RSEVP27MAN250

DN valve	Description	References PN10	References PN16	References PN25
<i>mm</i>	<i>Version</i>			
700	Manually	please contact us	please contact us	please contact us
800	Manually	please contact us	please contact us	please contact us
900	Manually	please contact us	please contact us	please contact us
1000	Manually	please contact us	please contact us	please contact us
1200	Manually	please contact us	please contact us	please contact us
1400	Manually	please contact us	please contact us	please contact us
1500	Manually	please contact us	please contact us	please contact us
1600	Manually	please contact us	please contact us	please contact us
1800	Manually	please contact us	please contact us	please contact us
2000	Manually	please contact us	please contact us	please contact us

ISOLATING VALVES
VALVES
 DN 150 to 2000



03/11/2021

RSEVP27MAN250

Material and coating

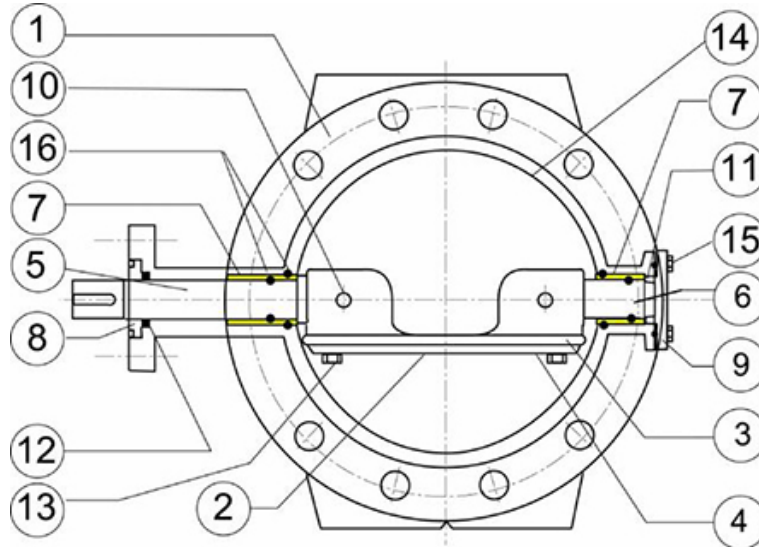

Item	Description	Material	Coating
1	Body	Ductile Iron GS500-7	Epoxy powder thickness mini 300 microns
2	Disc	Ductile Iron GS500-7	
3	Sealing ring	EPDM	-
4	Retaining ring	Stainless Steel AISI 316L	-
5	Shaft	Stainless steel DUPLEX EN 10088 1.4462 (X2CrNiMoN 22-5-3)	-
6	Spindle		-
7	Bearings	Bronze EN 1982 CuSn12	-
8	Ring	Gunmetal EN 1982 CuSn5Zn5Pb5	-
9	Rear cover	Steel type SR235JR	Epoxy powder thickness mini 300 microns
10	Taper pin	Stainless steel EN 10088-3 X5CrNiCuNb 16-4 (630)	-
11	Lock nut	Gunmetal EN 1982 CuSn5Zn5Pb5	-
12	Sealing element	PTFE	-
13	Internal Screw	Stainless steel type A4	-
14	Body seat ring	Stainless steel EN 10088-2 X2CrNiMo 17,12,2 (316L)	-
15	External Screw	Stainless steel type A4	-
16	O-ring gasket	EPDM WRAS 60	-

ISOLATING VALVES
VALVES
 DN 150 to 2000



03/11/2021

RSEVP27MAN250

Dimensions and mass

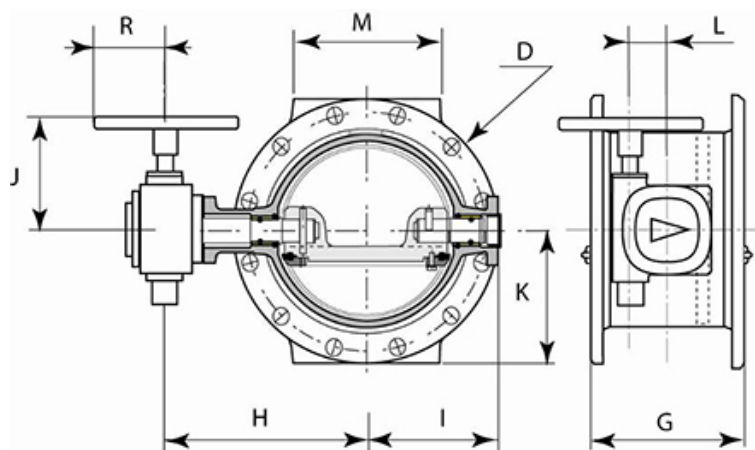

Manual Version PN10

DN	G	H	I	J	K	L	M	D	R	Mass clockwise	Mass anti clockwise
<i>mm</i>	<i>mm</i>	<i>mm</i>	<i>mm</i>	<i>mm</i>	<i>mm</i>	<i>mm</i>	<i>mm</i>	<i>mm</i>	<i>mm</i>	<i>kg</i>	<i>kg</i>
150	210	215	142.9	164	143	50	150	285	100	35	36
200	230	240	171.0	164	170	50	180	340	100	46	49
250	250	292	215.3	164	200	50	230	400	100	67	81
300	270	316	239.3	164	228	50	250	455	100	86	101
350	290	340	258.3	201	253	63	260	505	125	111	123
400	310	371	311.4	201	283	63	310	565	125	139	159
450	330	427	342.4	206	308	80	340	615	125	183	183
500	350	452	367.4	206	335	80	320	670	125	215	254
600	390	524	421.4	268	390	100	300	780	175	302	319
700	430	594	495.5	337	448	100	440	895	175	453	497
800	470	675	569.5	342	508	125	480	1015	175	640	793
900	510	724	623	342	558	125	570	1115	175	861	-
1000	550	815	707	48	615	160	620	1230	175	1249	-
1200	630	909	842	548	728	200	750	1455	175	1831	-
1400	710	1051	953	595	838	250	850	1675	250	2512	-
1500	750	1102	1004	595	893	250	900	1785	250	2873	-
1600	790	1154	1056	595	958	250	950	1915	250	3470	-
1800	870	1331	1179	755	1058	315	1000	2115	250	4965	-
2000	950	1526	1367	848	1173	400	1050	2345	400	6560	-

ISOLATING VALVES
VALVES
 DN 150 to 2000



03/11/2021

RSEVP27MAN250

Manual Version PN16

DN	G	H	I	J	K	L	M	D	R	Mass clockwise	Mass anti clockwise
<i>mm</i>	<i>mm</i>	<i>mm</i>	<i>mm</i>	<i>mm</i>	<i>mm</i>	<i>mm</i>	<i>mm</i>	<i>mm</i>	<i>mm</i>	<i>kg</i>	<i>kg</i>
150	210	215	142.9	164	143	50	150	285	100	35	36
200	230	240	171.9	164	170	50	180	340	100	46	49
250	250	292	215.3	164	200	50	230	400	100	67	-
300	270	321	239.3	201	228	63	250	455	125	88	101
350	290	340	280.4	201	260	63	260	520	125	132	150
400	310	407	322.4	206	290	80	310	580	125	170	216
450	330	427	342.4	206	320	80	340	640	125	207	252
500	350	470	367.4	248	358	100	320	715	175	265	307
600	390	550	451.5	334	420	100	300	840	175	414	476
700	430	627	521.5	340	455	125	440	910	175	543	675
800	470	713	602	415	513	160	480	1025	175	986	-
900	510	764	653	415	563	160	570	1125	175	1021	-
1000	550	815	748	545	628	200	620	1255	175	1432	-
1200	630	950	852	622	743	250	750	1485	250	2357	-
1400	710	1125	973	755	843	315	850	1685	250	3500	-
1500	750	1156	1077	755	933	315	900	1865	250	4281	-
1600	790	1229	1119	755	965	315	950	1930	250	4916	-
1800	870	1431	1272	848	1065	400	1000	2130	400	6974	-
2000	950	1526	1367	848	1173	400	1050	2345	400	8500	-

ISOLATING VALVES
VALVES
DN 150 to 2000



03/11/2021

RSEVP27MAN250

Manual Version PN25

DN	G	H	I	J	K	L	M	D	R	Mass clockwise	Mass anti clockwise
<i>mm</i>	<i>mm</i>	<i>mm</i>	<i>mm</i>	<i>mm</i>	<i>mm</i>	<i>mm</i>	<i>mm</i>	<i>mm</i>	<i>mm</i>	<i>kg</i>	<i>kg</i>
150	210	217	147.9	164	150	50	150	300	100	39	-
200	230	269	190.3	164	180	50	180	360	100	63	-
250	250	297	214.3	201	213	63	230	425	125	88	-
300	270	321	260.4	201	243	63	250	485	125	120	-
350	290	376	290.4	206	278	80	310	555	125	174	174
400	310	425	321.4	248	310	100	310	620	175	221	249
450	330	471	371.4	334	335	100	340	670	175	300	280
500	350	498	398.5	334	365	100	320	730	175	348	404
600	390	581	474.5	340	423	125	380	845	175	636	636
700	430	665	552	415	480	160	470	960	175	975	-
800	470	713	645	545	543	200	480	1085	175	1130	-
900	510	788	695	545	593	200	570	1185	175	1693	-
1000	550	856	756	622	660	250	620	1320	250	2091	-
1200	630	1024	872	750	765	315	750	1530	250	3398	3430
1400	710	1126	1016	750	878	315	850	1755	250	4067	-
1500	750	1186	1078	843	933	400	900	1865	400	6052	-
1600	790	1328	1169	843	988	400	950	1975	400	6200	-

Gearbox type and handwheel

Manual type PN10

DN <i>mm</i>	Gearbox AUMA type	Handwheel Ø	Number of turns at 90°	Operating torque	Ø stem gearbox
		<i>mm</i>		<i>Nm</i>	<i>mm</i>
150	GS 50.3 – F10	200	12,75	8	16
200	GS 50.3 – F10	200	12,75	12	16
250	GS 50.3 – F10	200	12,75	21	16
300	GS 50.3 – F10	200	12,75	30	16
350	GS 63.3 – F12	250	12,75	40	20
400	GS 63.3 – F12	250	12,75	61	20
450	GS 80.3 – F14	250	13,25	72	20
500	GS 80.3 – F14	250	13,25	92	20
600	GS 100.3 – F16	350	13	133	20
700	GS 100.3+VZ4.3 – F16	350	52	52	20
800	GS 125.3+VZ4.3 – F25	350	52	77	20
900	GS 125.3+VZ4.3 – F25	350	52	100	20
1000	GS 160.3+GZ160.3 - F30	350	110,5	65	20
1200	GS 200.3+GZ200.3 - F30	350	213	74	20

ISOLATING VALVES
VALVES
 DN 150 to 2000



03/11/2021

RSEVP27MAN250

DN <i>mm</i>	Gearbox AUMA type	Handwheel Ø	Number of turns at 90°	Operating torque	Ø stem gearbox
		<i>mm</i>		<i>Nm</i>	<i>mm</i>
1400	GS 250.3+GZ250.3 - F35	500	212	93	30
1500	GS 250.3+GZ250.3 - F35	500	212	110	30
1600	GS 250.3+GZ250.3 - F35	500	212	130	30
1800	GS 315+GZ30 - F40	500	424	75	20
2000	GS 315+GZ30 - F40	800	432	117	30

ISOLATING VALVES
VALVES
DN 150 to 2000



03/11/2021

RSEVP27MAN250

Manual type PN16

DN <i>mm</i>	Gearbox AUMA type	Handwheel Ø	Number of turns at 90°	Operating torque	Ø stem gearbox
		<i>mm</i>		<i>Nm</i>	<i>mm</i>
150	GS 50.3 – F10	200	12,75	8	16
200	GS 50.3 – F10	200	12,75	17	16
250	GS 50.3 – F10	200	12,75	29	16
300	GS 63.3 – F12	250	12,75	43	20
350	GS 63.3 – F12	250	12,75	60	20
400	GS 80.3 – F14	250	13,25	84	20
450	GS 80.3 – F14	250	13,25	112	20
500	GS 100.3 – F14	350	13	125	20
600	GS 100.3+VZ4.3 – F16	350	52	59	20
700	GS 125.3+VZ4.3 – F25	350	52	84	20
800	GS 160.3+GZ160.3 – F30	350	110,5	64	20
900	GS 160.3+GZ160.3 – F30	350	110,5	83	20
1000	GS 200.3+GZ200.3 - F30	350	216	65	20
1200	GS 250.3+GZ250.3 - F35	500	212	104	30
1400	GS 315+GZ30 - F40	500	424	65	20
1500	GS 315+GZ30 - F40	500	424	77	20
1600	GS 315+GZ30 - F40	500	424	94	30
1800	GS 400+GZ35 - F48	800	432	126	30
2000	GS 400+GZ35 - F48	800	432	161	30

ISOLATING VALVES
VALVES
DN 150 to 2000



03/11/2021

RSEVP27MAN250

Manual type PN25

DN <i>mm</i>	Gearbox AUMA type	Handwheel Ø	Number of turns at 90°	Operating torque	Ø stem gearbox
		<i>mm</i>		<i>Nm</i>	<i>mm</i>
150	GS 50.3 – F10	200	12,75	13	16
200	GS 50.3 – F10	200	12,75	28	16
250	GS 63.3 – F12	250	12,75	45	20
300	GS 63.3 – F12	250	12,75	71	20
350	GS 80.3 – F14	250	13,25	89	20
400	GS 100.3 – F14	350	13	122	20
450	GS 100.3+VZ4.3 – F16	350	52	45	20
500	GS 100.3+VZ4.3 – F16	350	52	59	20
600	GS 125.3+VZ4.3 – F25	350	52	100	20
700	GS 160.3+GZ160.3 – F30	350	110,5	70	20
800	GS 200.3+GZ200.3 – F30	350	216	66	20
900	GS 200.3+GZ200.3 – F35	350	216	84	20
1000	GS 250.3+GZ250.3 – F35	500	212	115	30
1200	GS 315+GZ30 – F40	500	424	74	20
1400	GS 315+GZ30 – F40	500	424	110	30
1500	GS 400+GZ35 – F48	800	432	133	30
1600	GS 400+GZ35 – F48	800	432	153	30

Applicable Standards

Hydraulic test

Every single butterfly valve is subjected to hydraulic final test with the purpose of verifying the accordance with the prescriptions ISO 5208:

- Body test at 1,5 time the PFA (open valve);
- Seat test at 1,1 time the PFA (closed valve).

Product test

- Control of manoeuvre torque (MOT and mST) as defined in the EN1074
- Control of coating: test of thickness, holiday test, impact test, MIBK test

Conformity to the standards

Product:

- EN 1074 – 1 and 2
- EN 593
- ISO 10631

Plant test:

- ISO 5208

ISOLATING VALVES VALVES DN 150 to 2000		03/11/2021
		RSEVP27MAN250

Flanges dimension:

- ISO 5752 series 14

Flanges drilling:

- EN 1092-2
- ISO 7005-2

Suitability for potable water:

- Italian CM 102 of 02/12/78
- Conformity to foreign norms: KTW (Germany), WRC (U.K.), ACS (France)

Marking

On the body like EN19:

- Nominal diameter in mm (DN);
- Nominal pressure in bar (PN);
- Type of ductile iron;
- Manufacturer's logo;
- Model code;
- Fusion date.

On the label like EN19:

- Nominal diameter in mm (DN);
- Nominal pressure in bar (PN);
- Maximum operating pressure (PFA);
- Closing direction;
- Model code;
- Manufacturing order, Order confirmation;
- Manufacturer's logo.

On the disc:

- Nominal diameter in mm (DN);
- Nominal pressure in bar (PN);
- Type of ductile iron;
- Manufacturer's logo;
- Model code.

The marking of the valves manufactured by Saint-Gobain refers to the EN 1074-2 and EN 19 international standards.

Markings are either integral markings, cast in the body, or markings made on plates, securely fixed to the body, in accordance with the EN 19 standard specifications.

Specifications EN19		Requirements	Saint-Gobain valves process
Table1-Valve markings			
1	DN	EN 19 § 4.2.1	Integral

ISOLATING VALVES VALVES DN 150 to 2000		03/11/2021
		RSEVP27MAN250

Specifications EN19			Saint-Gobain valves process
Table1-Valve markings		Requirements	
2	PN	Mandatory markings Shall be integral markings or on a marking plate	Integral
3	Material		Integral
4	Manufacturer's name or trade mark		Plate
11	Reference to Standard	EN 19 § 4.3	Integral
12	Melt identification		Integral
16	Quality test	Supplementary markings	Printed on body
18	Manufacturing date	Items 7 to 21 in Table 1 are optional	Plate
21	Closing direction		Plate + sticker on body



Valve selection

The butterfly valves are generally used as isolating devices type on/off. In some particular case, in which there's low differences of pressure and low flow rate variation can be used like regulating devices, considering the hydraulic parameters necessary to avoid the cavitation risk.

To do the right dimensioning of butterfly valve it's necessary to know the followings parameters:

- Upstream hydrostatic pressure (that is the hydrostatic pressure with valve in closed position)
- The maximum speed in water pipe (generally expressed in l/s) or the nominal diameter and the project flow rate from which it is gained the speed $V=Q/A$

Moreover it's necessary to control that the maximum speed in water pipe have to be equal or inferior to 5m/s, and the exercise temperature have to be between 0°C and 40 °C.

Hydraulic features

The head loss Δh are variable in function of valve open degree and can be calculated with the following expression:

$$\Delta h = \frac{\zeta \cdot v^2}{2 \cdot g}$$

with Δh = head loss (m), ζ = head loss coefficient (dimensional), v = nominal speed (m/s), $g = 9,81$ (m/s²)

The head loss coefficient can be estimated from this diagram:

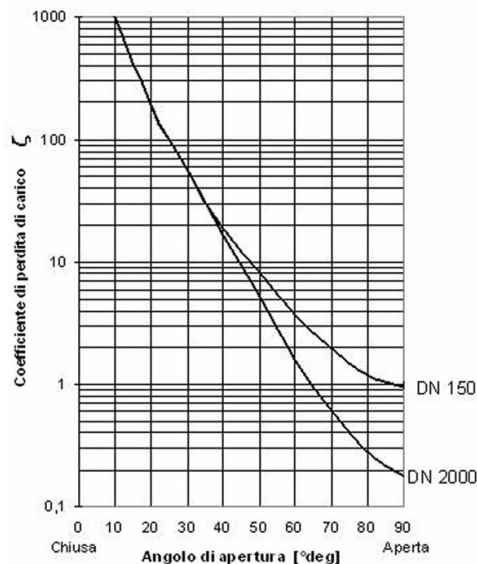

Determinates the head loss Δh it's possible to calculate the flow rate Q in m³/h with the following expression (the same expression can be used to, having the project flow rate Q , to determinate the head loss Δh without using the head loss coefficient):

$$Q = K_v \sqrt{\frac{\Delta h}{10.2}}$$

in which 10,2 is a corrective factor in meters, and K_v is the flow rate coefficient in m³/h, determinable from the following diagram in function of valve open degree:

VALVOLA A FARFALLA - BUTTERFLY VALVE

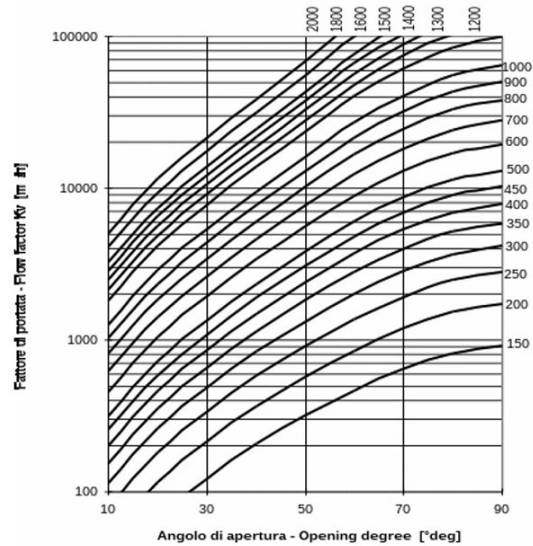

Example: Valve DN600 mm - $\Delta h = 3$ m

From the diagram with valve open to 100% the coefficient Kv is 20000 m³/h. Using this date in the flow rate expression:

$$Q = 20000 \times \sqrt{\frac{3}{10,2}} = 10850 \text{ m}^3/\text{h}$$

Otherwise it's possible to calculate the head loss with valve completely open, having the project flow rate Q, in function of DN, using the following diagram:

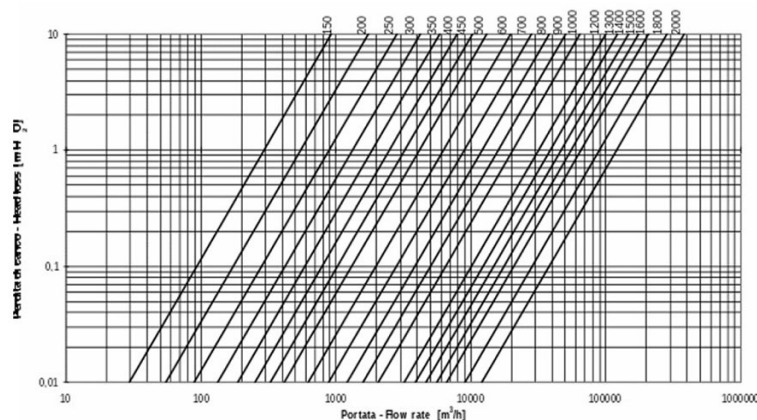

Cavitation

If the butterfly valve is used only like isolating device there's not cavitation risk.

In the particular case in which it's used like regulating device, this can be possible only respecting the following parameters:

- The valve open degree have to be between 30° and 90° (valve completely open)
- The downstream pressure P₂ have to be: $P_2 \geq 0,7 \cdot P_1 - 2,8$ with P₁ upstream pressure.

ISOLATING VALVES VALVES DN 150 to 2000		03/11/2021
		RSEVP27MAN250

Instructions for use

Storage

The butterfly valve will have to be held (if possible) in covered places, the most possible protected from the sun (maximum allowable temperature 70°C in accordance to EN 1074), from the rain and generally from the atmospheric agents. Moreover it will have to be avoided that the seal of the same air valves come to contact with powder or earth.

Installation

The butterfly valves are generally installed with retaining ring mounted in the opposite way respect to the direction of flow rate to permit the substitution of gasket without dismounting the valve from pipeline. In any case it is possible to install the butterfly valve with flow rate in opposite direction and also, if required, in vertical position. We recommend to install the butterfly with the operating device on the hydraulic right side of pipeline.

It's possible to install the butterfly valve both in chamber valve that underground (choosing the right configuration).

We recommend to insert a dismounting joint for the operation of maintenance.

Maintenance

The butterfly valve does not require a particular maintenance, all parts subjected to wear are perfectly auto-lubricating. In any case, if for a long time will be not used, it is necessary to evaluate the functioning of valve doing (at least one time for year) some manoeuvre of opening-closing.

All the maintenance operation have to be do after the total emptying of pipeline (no flow rate and pressure) to avoid every risk to the people during this operation.

In presence of particularly exercise condition or damage due to external cause, it will be necessary some maintenance operation. In this case the particular shape of EUROSTOP butterfly valve permits the simple gasket substitution without the dismounting of valve from pipeline (if the dismounting joint is present).

Accessories

To adapt the butterfly valves to the different exercise and installation conditions required, they can be equipped with particular accessories used in combination with control devices: please refer to data sheet for accessories.

The technical features in this document are not contractual and can be changed without preliminary notification due to the continuous technical progress of product.